

1

2

3

4

REV	ECN#	DESCRIPTION OF REVISION	DRAW BY DATE	CHECK BY DATE	APPROVE BY DATE
A0			Lucas 11/01/23	Lucas 11/01/23	Ray 11/01/23

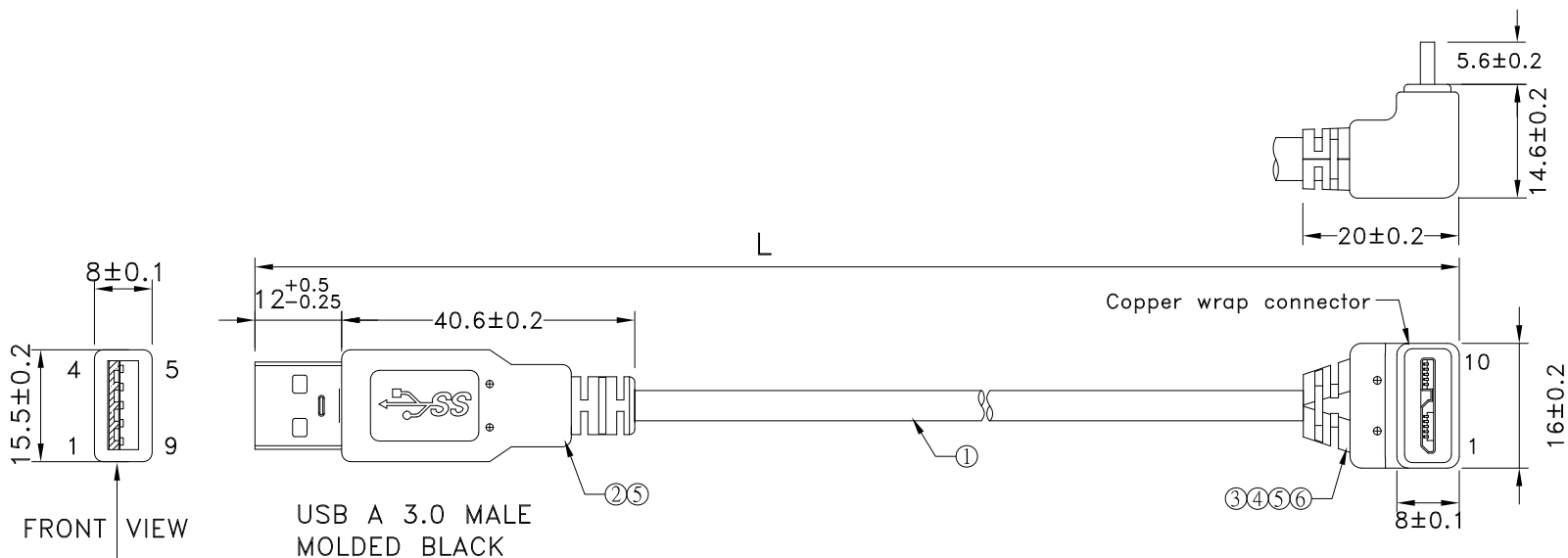

PIN OUT

USB A M		Micro-USB BM
1	RED	1
2	WHITE	2
3	GREEN	3
4	BLACK	5
5	BLUE	6
6	YELLOW	7
7	DRAIN	8
8	PURPLE	9
9	ORANGE	10
SHEEL	BRAID	SHEEL

Micro USB BM
RIGHT ANGLE DOWN
MOLDED BLACK



P/N	LENGTH
RR-ASMD-06GRX	153 ⁺²⁰ ₋₀
RR-ASMD-10GRX	255 ⁺³⁰ ₋₀
RR-ASMD-20GRX	508 ⁺³⁰ ₋₀
RR-ASMD-40GRX	1016 ⁺³⁰ ₋₀
RR-ASMD-78GRX	1980 ⁺⁶⁰ ₋₀

TITLE USB3.0 AM TO Micro-BM RIGHT ANGLE DOWN					DRAWING NUMBER RR-ASMD-XXGRX			REV. A0	
THIRD ANGLE PROJECTION	SIZE B	SCALE 1:1	DRAW / DATE Lucas 11/01/23	CHECK / DATE Lucas 11/01/23	APPROVE / DATE Ray 11/01/23	TOLERANCES X.X ± 0.5 X.XX ± 0.2	ANGLES X.XXX ± 0.05 X.X ± 1°	UNIT mm	SHEET 1/3

USB FIREWIRE.com

THE INFORMATION CONTAINED HEREIN IS PROPRIETARY AND CONFIDENTIAL TO RR BUSINESS VENTURES, LLC. THE POSSESSOR AGREES TO THE FOLLOWING

1. MAINTAIN THIS DOCUMENT IN CONFIDENCE
2. NOT TO REPRODUCE OR COPY IT
3. NOT TO REVEAL OR PUBLISH IT IN WHOLE OR PART

1

2

3

4

1

2

3

4

REV	ECN#	DESCRIPTION OF REVISION	DRAW BY DATE	CHECK BY DATE	APPROVE BY DATE
A0			Lucas 11/01/23	Lucas 11/01/23	Ray 11/01/23

ITEM	Part name	MATERIAL/FINISH	Q.ty
1	Cable	UL2725 (1P/32#+EAM)*2+(1P/32#)+(2C/28#)+AEB 65% OD:4.2mm BLACK PVC JACKET	1
2	USB 3.0 AM	USB3.0 A TYPE 9PIN MALE SOLDER TYPE	1
		PINS: 30u GOLD PLATED OVER NICKEL	
		INSULATOR: BLUE COLOR P.B.T UL 94V-0 RATED	
		SHELL: STEEL WITH GOLD FLASH	
3	Micro-USB BM	Micro-USB 3.0 B TYPE MALE SOLDER TYPE	1
		PINS: 30u GOLD PLATED OVER NICKEL	
		INSULATOR: BLACK COLOR P.B.T UL 94V-0 RATED	
		SHELL: STEEL WITH GOLD FLASH	
4	inner Mold	HENKEL: A2035 94A	AR
5	Over Mold	BLACK PVC 45P	AR
6	Copper foil	Copper foil	AR



TITLE USB3.0 AM TO Micro-BM RIGHT ANGLE DOWN					DRAWING NUMBER RR-ASMD-XXGRX			REV. A0
DO NOT SCALE DRAWINGS	B	1:1	Lucas 11/01/23	Lucas 11/01/23	Ray 11/01/23	X.X ± 0.5 X.XX ± 0.2	X.XXX ± 0.05 ANGLES ± 1°	mm 2/3
THIRD ANGLE PROJECTION	SIZE	SCALE	DRAW / DATE	CHECK / DATE	APPROVE / DATE	TOLERANCES		UNIT SHEET

THE INFORMATION CONTAINED HEREIN IS PROPRIETARY AND CONFIDENTIAL TO RR BUSINESS VENTURES, LLC. THE POSSESSOR AGREES TO THE FOLLOWING

1. MAINTAIN THIS DOCUMENT IN CONFIDENCE
2. NOT TO REPRODUCE OR COPY IT
3. NOT TO REVEAL OR PUBLISH IT IN WHOLE OR PART

1

2

3

4

1

2

3

4

REV	ECN#	DESCRIPTION OF REVISION	DRAW BY DATE	CHECK BY DATE	APPROVE BY DATE
A0			Lucas 11/01/23	Lucas 11/01/23	Ray 11/01/23

P/N	LENGTH(mm)	PE BAG(Inch)	PACKAGE
RR-ASMD-06GRX	153 ⁺²⁰ ₋₀	5.5"*10	(1)
RR-ASMD-10GRX	255 ⁺³⁰ ₋₀	5.5"*10	(2)
RR-ASMD-20GRX	508 ⁺³⁰ ₋₀	5.5"*10	(2)
RR-ASMD-40GRX	1016 ⁺³⁰ ₋₀	5.5"*10	(3)
RR-ASMD-78GRX	1980 ⁺⁶⁰ ₋₀	5.5"*10	(3)

PE BAG LABEL

RR-ASMD-XXGRX REV:XX
 LOT: XXXX
 Made in China

75mm

RR-ASMD-XXGRX REV:XX QTY:25PCS
 LOT: XXXX
 Made in China

RoHS LABEL

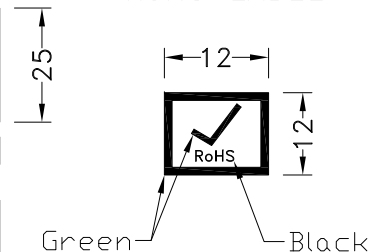

NOTES:PACK EACH CABLE IN A POLY BAG AND 25PCS IN A POLY BAG.

PACK(1)

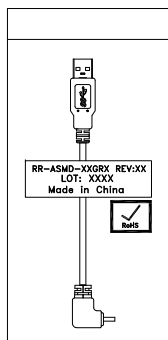

PACK(2)

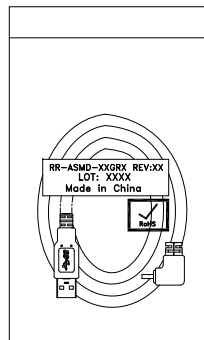

PACK(3)

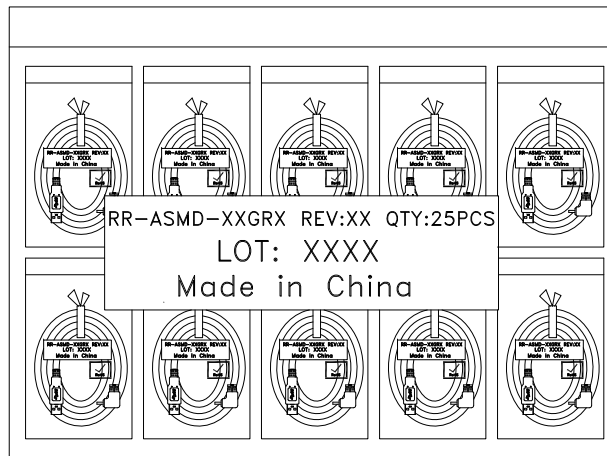
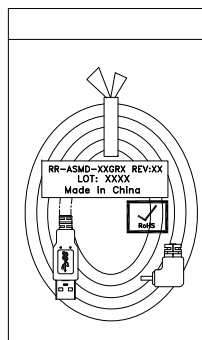

GTC
 DOC.CENTER.ISSUE
 NOV.01.2023
 ONLY FOR
 RELEASE

TITLE: USB3.0 AM TO Micro-BM RIGHT ANGLE DOWN
 DRAWING NUMBER: RR-ASMD-XXGRX
 REV: A0

THIRD ANGLE PROJECTION	SIZE	SCALE	DRAW / DATE	CHECK / DATE	APPROVE / DATE	TOLERANCES	UNIT	SHEET
	B	1:1	Lucas 11/01/23	Lucas 11/01/23	Ray 11/01/23	X.X ± 0.5 X.XX ± 0.2	mm	3/3
						X.XXX ± 0.05 ANGLES ± 1°		

THE INFORMATION CONTAINED HEREIN IS PROPRIETARY AND CONFIDENTIAL TO RR BUSINESS VENTURES, LLC. THE POSSESSOR AGREES TO THE FOLLOWING

1. MAINTAIN THIS DOCUMENT IN CONFIDENCE
2. NOT TO REPRODUCE OR COPY IT
3. NOT TO REVEAL OR PUBLISH IT IN WHOLE OR PART

1

2

3

4