

CHANGE VERSION	REMARKS	C	11/06/05	CFM AF TOOLING SIZE	
A	11/04/30	REL	D	12/08/10	REMOVE STICKER, CHANGE PIN TO 30U
B	11/05/25	CFM TOLERANCE, CHANGE AF ELCLOSED TYPE	E		

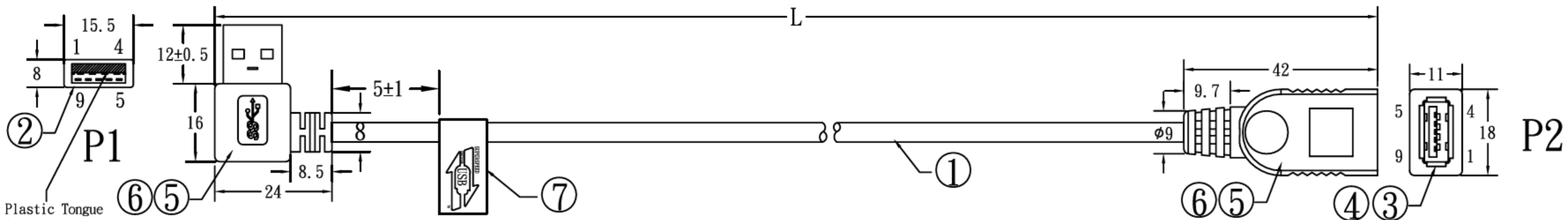

**PIN OUT:**

P1	P2
1	1 RD
2	2 WH
3	3 GN
4	4 BK
5	5 BL
6	6 YL
7	7 SDP DRAIN
8	8 PR
9	9 OR
S	S DRAIN

RR-ARAF-06GR	45mm	15mm
RR-ARAF-10GR	15mm	15mm
RR-ARAF-20GR	15mm	15mm
RR-ARAF-40GR	15mm	15mm
RR-ARAF-78GR	15mm	15mm

P/N	LENGTH	PE BAG	PACKAGE
RR-ARAF-06GR	153 <sup>+20</sup> <sub>-0</sub>	06*3"*8"	(1)
RR-ARAF-10GR	255 <sup>+20</sup> <sub>-0</sub>	06*3"*8"	(1)
RR-ARAF-20GR	508 <sup>+30</sup> <sub>-0</sub>	06*3"*8"	(2)
RR-ARAF-40GR	1016 <sup>+40</sup> <sub>-0</sub>	06*3"*8"	(2)
RR-ARAF-78GR	1980 <sup>+60</sup> <sub>-0</sub>	06*6"*8"	(3)

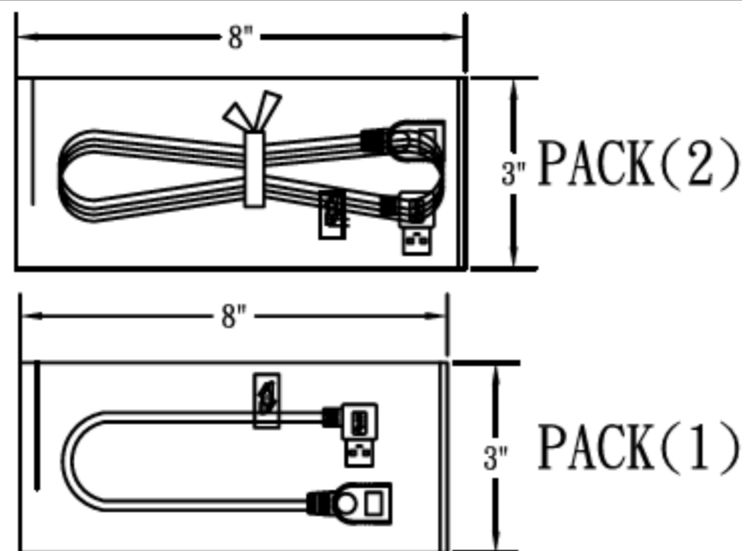

P/N STICKER

**RoHS**

**MATERIAL LIST :**

NO.	P/NAME	DESCRIPTION	Q' TY
1	WIRE	UL20276 [28AWG(7/0.12 TC)*1P+1+AL+MYLAR]*2C+28AWG(7/0.12 TC)*1P+24AWG(7/0.20 TC)*2C+AL+1(BC)+80B(AM) OD:5.5±0.15 BLACK(B792) USB3.0 VERSION	1
2	PLUG	USB3.0 "A" TYPE MALE PIN=30u" GOLD PLATED SHORT TYPE	1
3	PLUG	USB3.0 "A" TYPE FEMALE PIN=30u" GOLD PLATED	1
4	TINPLATE	USB TINPLATE	1
5	PVC	LD PE	4g
6	PVC	45P BLACK(B792)PVC	14g
7	PACKAGE	IPCE/PE BAG:06*A"*B", + P/N STICKER	1
			1

MOLD TOOL NO.
USB3.0 AM(RIGHT) A110-624-001 B120-296-001
"A" TYPE 3.0 F A110-688-001 B120-334-001

<a href="http://www.USBFireWire.com">www.USBFireWire.com</a>			
	SCALE	UNIT	REV
FILE NAME		MM	D
OW1104055			
DATE	CUSTOMER P/N		
12/08/10	RR-ARAF-XXGR		

DRAWN BY	Marcos
CHECKED BY	
CONFIRMED BY	
CHECKED BY	
APPROVED BY	