

Notes: (Unless Otherwise Specified)

1. Waterproof Rate: IP68.
2. Recommend Panel Thickness: 0.8 to 8.0 mm.
3. Recommend Torque: 19~20 Kgf-cm.
4. Mating Cap P/N: **RR-1C543122**
5. RoHS Compliant.

REV	ECN#	DESCRIPTION OF REVISION	DRAW BY DATE	CHECK BY DATE	APPROVE BY DATE
A0		Mass Production	Joyce 07/09/12	Lucas 07/09/12	Ray 07/09/12
A1	ECN-121114	Modify Label Type & Packing Q'ty 	Joyce 11/21/12	Lucas 11/21/12	Ray 11/21/12

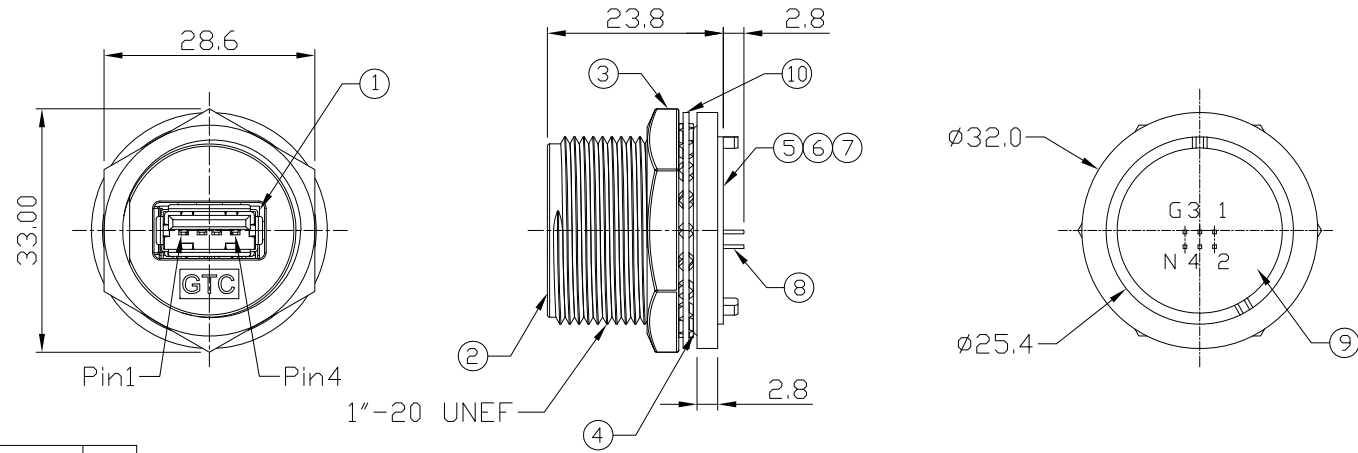

10	Metal Washer	Stainless Finish: —	1
9	Glue	Epoxy Color: Black	
8	Pin Header	Housing: Thermoplastic, Color: Black Contacts: Copper Alloy, Finish: Au Plated	1
7	PCB	FR-4 Color: —	1
6	EMI Shielded Plated	Zn Alloy Finish: Ni Plated	1
5	Holder	Thermoplastic Color: Black	1
4	O-Ring	Silicone Color: Red	1
3	Hex Nut	Zn Alloy Finish: Ni Plated	1
2	Housing	Zn Alloy Finish: Ni Plated	1
1	USB-A Receptacle	Housing: Thermoplastic, Color: Black Contacts: Copper Alloy, Finish: Au Plated Shell: Copper Alloy, Finish: Ni Plated	1
Item	Part Name	Material / Finish	Q'TY

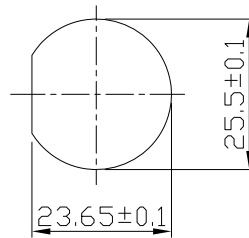

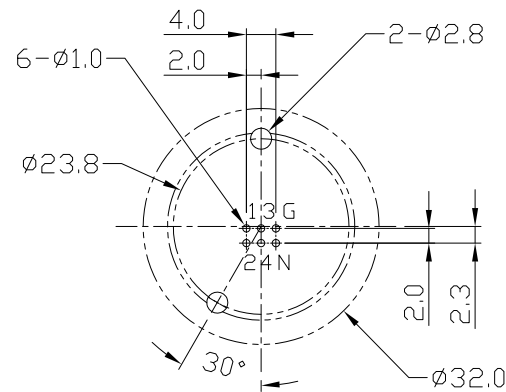

Recommend
Panel Cut-Out



Recommend PCB Layout

DOC.CENTER.ISSUE
NOV.29.2012
ONLY FOR
RELEASE

TITLE						DRAWING NUMBER			REV.
USB-A Metal C4 Panel Jack Dip Screw						RR-211300-10			A1
	B	1:1	Joyce 07/09/12	Lucas 07/09/12	Ray 07/09/12	X.X ± 0.5 X.XX ± 0.2	X.XXX ± 0.05 ANGLES ± 1°	mm	1/1
THIRD ANGLE PROJECTION	SIZE	SCALE	DRAW / DATE	CHECK / DATE	APPROVE / DATE	TOLERANCES		UNIT	SHEET

USB FIREWIRE.com

THE INFORMATION CONTAINED HEREIN IS THE PROPRIETARY INFORMATION OF RR BUSINESS VENTURES, LLC. THE POSSESSOR AGREES TO THE FOLLOWING

1. MAINTAIN THIS DOCUMENT IN CONFIDENCE
2. NOT TO REPRODUCE OR COPY IT
3. NOT TO REVEAL OR PUBLISH IT IN WHOLE OR IN PART

COPYRIGHT © 2019